

APPC SERIES

COMPACT PLASMA

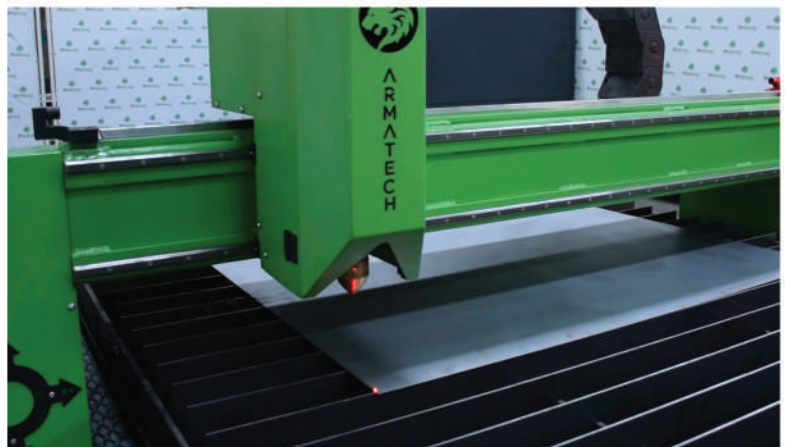
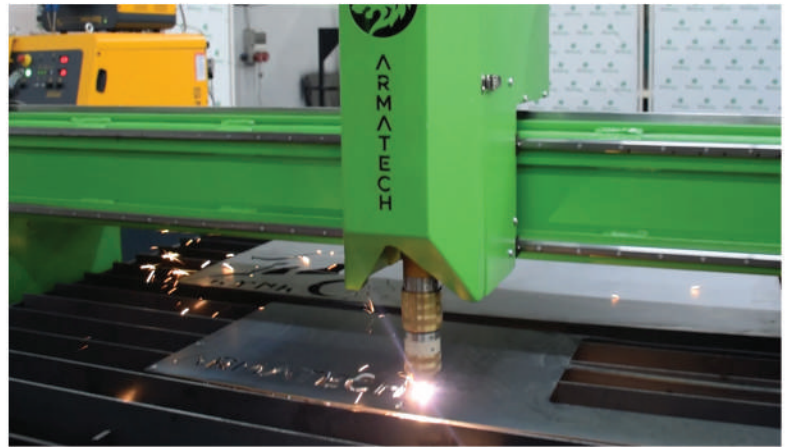

Main Features

- 17" LCD Industrial Touch Screen
- Windows Based Cnc Controller
- Operator Panel
- Safe Module Inputs and Outputs
- Remote Connection Interface
- THC Automatic Height Control System
- Nozzle Sensor
- TORCH Collision Sensor
- 200 mm Standard Stroke
- Laser Pointer
- 3 Axis (X, Y,Z) Movement
- Servo Motor and drivers set
- Planetary Gearbox
- High Precision Linear Rails
- High Precision Helix Gear and Creamer
- Cable Channels on X,Y, Z Axes
- Table with Cnc Controlled Pneumatic System
- Fixed Control Panel System
- 3 Emergency Buttons
- Troubleshooting and service opportunity with remote connection
- Nesting Program

Optional Features

- Plasma Fume Extraction Unit
- 4000 = 4000m³/hour flow
- 6000 = 6000m³/hour flow
- Cooler to Electrical Panel depends on the Working Environment
- Optional Electrical Voltage
- Jet Filter

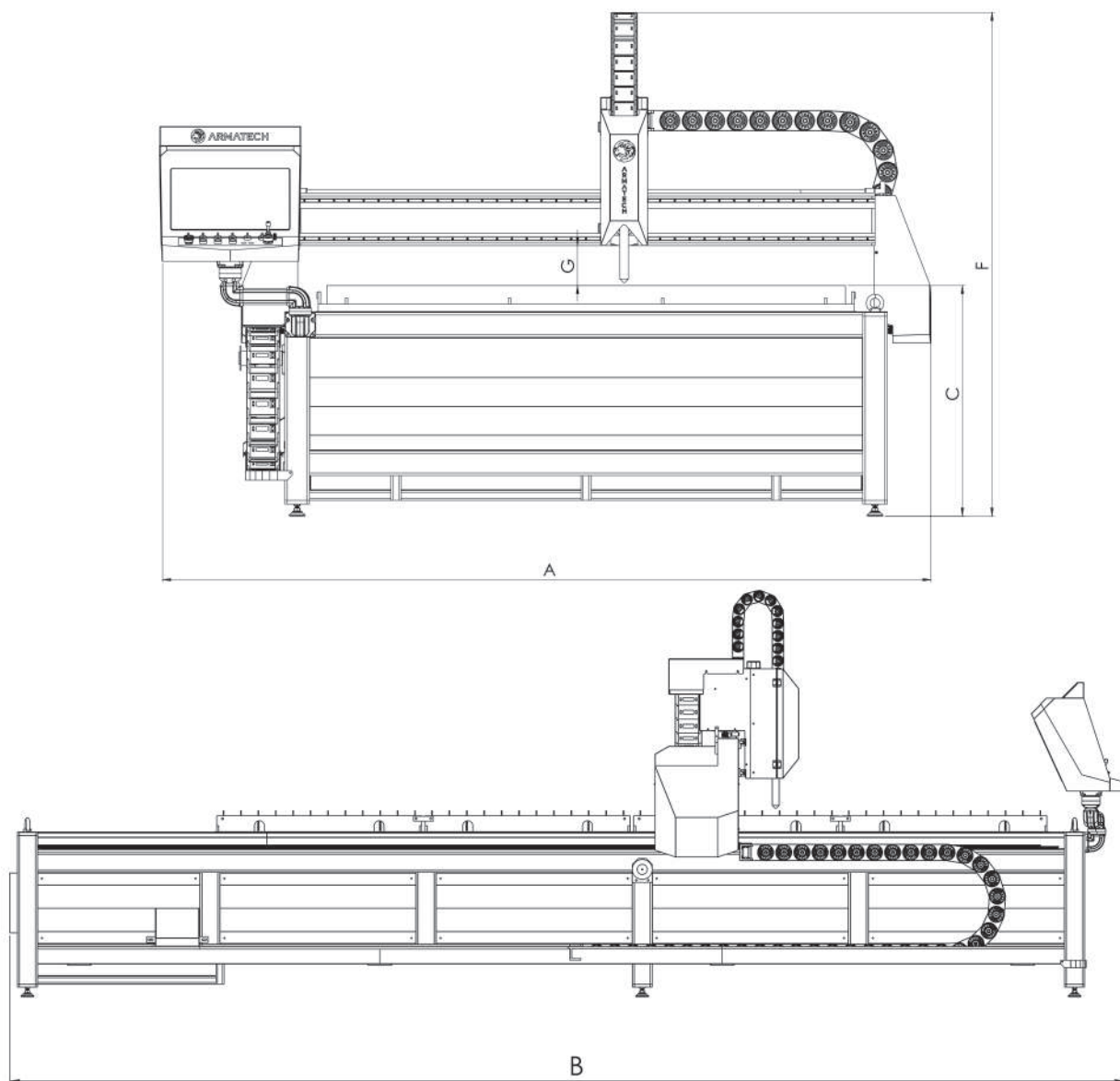

APPC SERIES COMPACT TYPE PLASMA CUTTING MACHINES

SPECIFICATIONS		APPC 1530 (COMPACT)	APPC 2040 (COMPACT)	APPC 2060 (COMPACT)
A	TOTAL WIDTH (mm)	2615	3115	3115
B	TOTAL LENGTH (mm)	4620	5620	6620
C	CUTTING TABLE HEIGHT (mm)	920	920	920
D	WORKING WIDTH (mm)	1670	2170	2170
E	WORKING LENGTH (mm)	3110	4160	6250
F	TOTAL HEIGHT (mm)	2035	2035	2035
G	DISTANCE BETWEEN BRIDGE AND WORK TABLE (mm)	165	165	165

Kjellberg[®]
FINSTERWALDE

Welding

Engineering

PLASMA CUTTING

**SMART
FOCUS**



Smart Focus Pure Energy

Smart Focus 130, 170, 200, 300, 400

Plasmaschneiden von 1 bis 100 mm

Plasma cutting from 1 to 100 mm



kjellberg.de

Plasmaschneiden von 1 bis 100 mm

Plasma Cutting from 1 to 100 mm

Vorteile

- Höchste Schnittqualität
- Hohe Schneidgeschwindigkeit
- Geringe Rechtwinkligkeitstoleranz
- Bediener- & servicefreundlich
- Geringe Schnittmeterkosten

Advantages

- Highest cutting quality
- High cutting speed
- High perpendicularity tolerance
- User-friendly & easy to service
- Low costs per cutting metre

Schneidbereich | Cutting range mm

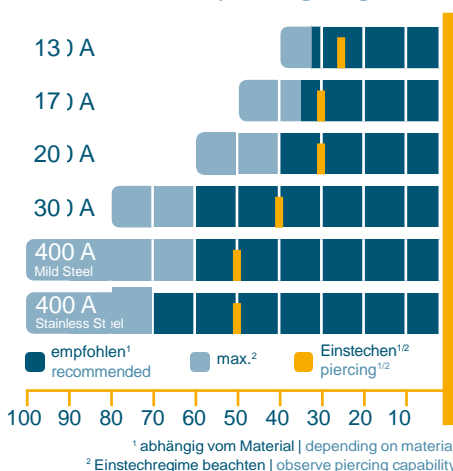

Einfach gut schneiden

Mit den kompakten Anlagen der Smart Focus-Reihe werden mit nur wenigen Einstellungen exzellente Schneidergebnisse im Materialdickenbereich von 1 bis 100 mm erzielt – selbst unter anspruchsvollsten Bedingungen. Das Markieren, Fasen- und Unterwasser-Plasmaschneiden ist mit den Smart Focus-Anlagen ebenfalls möglich – made in Germany.

Simply good cutting

With just a few settings the compact plasma cutting units of the Smart Focus series achieve excellent results in the cutting range from 1 to 100 mm – even under most challenging conditions. The Smart Focus units can also be used for marking, bevel and underwater cutting – made in Germany.

Baustahlschneiden mit Contour Cut & Silent Cut

Mit der bewährten Contour Cut-Technologie werden in Baustahl kleine Konturen, schmale Stege und Löcher im Verhältnis 1:1 von Durchmesser zu Materialstärke in ausgezeichneter Qualität geschnitten. Mit Contour Cut Speed können Konturen bis zu 50 % schneller geschnitten werden. Als Weiterentwicklung der Contour Cut-Technologie reduziert die neue Silent Cut-Technologie im Stromstärkenbereich von 60 bis 170 A den Schalldruckpegel beim Schneiden um bis zu 15 dB(A). Möglich wird dies durch neue Verschleißteile und die Verwendung der Silent Cut-Schneid-datenbank – bei ähnlicher Schnittqualität.

Mild steel cutting with Contour Cut & Silent Cut

With the well-proven Contour Cut technology small contours, narrow webs and holes with a diameter to material thickness ratio of 1:1 can be cut in excellent quality in mild steel. Contour Cut Speed allows the cutting of contours with a speed that is up to 50 % faster. As a further development of Contour Cut the new Silent Cut technology reduces the sound pressure level by up to 15 dB(A) during cutting in the cutting range from 60 to 170 A. This is made possible by new consumables and the use of the Silent Cut cutting database – with similar cut quality.

contour cut

contour cut
SPEED

silent CUT



Moderne Komponenten Modern Components

Brenner & Gassteuerung – intelligente Technik

Für die Smart Focus-Reihe stehen wahlweise manuelle oder automatische Gassteuerungen zur Verfügung, die beste Schneidergebnisse mit höchster, reproduzierbarer Qualität erzielen. Die manuelle Gassteuerung PGE-300 ermöglicht jetzt das Schneiden mit Luft als Plasmagas.

Die Brenner PerCut 2000 und PerCut 4000 sind in Aufbau und Funktionsweise im Vergleich zu den Vorgängermodellen verbessert worden und ermöglichen präzise Schnitte und höchste Schneidgeschwindigkeiten. Ihre einzigartige Flüssigkeitskühlung bis in die Brennerspitze garantiert höchste Lebensdauer der Verschleißteile, reduziert den Gasverbrauch und damit auch die Schnittmeterkosten.

Torches & gas control – intelligent redevelopment

Either manual or automated gas supply units are available for the Smart Focus series. With these the user achieves best cutting results with highest, reproducible quality. The manual gas supply unit PGE-300 now allows for plasma cutting with air as plasma gas.

The new torches PerCut 2000 and PerCut 4000 have been improved compared to the preceding models. They provide precise cuts and highest cutting speeds. Their unique cooling system up to the torch tip guarantees longest consumable life and reduces the gas consumption and costs per cutting metre.



PerCut-Brenner: auch für Fasenschnitte bis 50° | PerCut torches: also for bevel cutting up to 50°



Verschleißteile mit langer Lebensdauer
Consumables with long lifetime



Gasversorgung manuell: PGE-300,
automatisch: PGV-300
Gas supply manual: PGE-300, automated: PGV-300

Schneidgeschwindigkeit mm/min, Baustahl
Cutting speed mm/min, mild steel

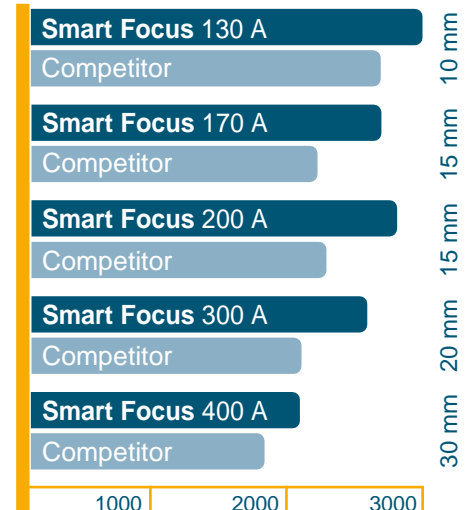

Brenner Torches	PerCut 2000, 4000
Schnellwechselkopf Quick-change head	PerCut 4000
Einspanndurchmesser Clamping diameter	50.8 mm 2 inches
Plasmagas Plasma gases	O ₂ , Ar/H ₂ , N ₂ , Air
Markiergas Marking gases	Ar, N ₂ , Air
Wirbelgas Swirl gases	O ₂ , N ₂ , F5 ³ , Air

³Formiergas | forming gas F5 (95 % N₂, 5 % H₂)

Einsatzgebiete

Metall- & Maschinenbau
Lohnzuschnitt
Stahl- & Hallenbau
Anlagen- & Behälterbau
Nutzfahrzeug- & Kranbau
Rohrleitungs- & Lüftungsbau
Schiff- & Automobilbau

Application areas

Metal construction & engineering
Job shop production
Steel & hall construction
Plant & tank construction
Commercial vehicle & crane construction
Pipeline & ventilation construction
Shipbuilding & automotive engineering

Technische Daten Technical data	Smart Focus 130	Smart Focus 170	Smart Focus 200	Smart Focus 300	Smart Focus 400
Netzspannung Mains voltage ¹	3x 400 V 50 Hz	3x 400 V 50 Hz	3x 400 V, 50 Hz	3x 400 V, 50 Hz	3x 400 V, 50 Hz
Sicherung, träge Fuse, slow	50 A	59 A	80 A	125 A	180 A
Anschlussleistung Connected load	max. 28 kVA	max. 41 kVA	max. 51 kVA	max. 79 kVA	max. 116 kVA
Schneidstrom Cutting current	35 – 130 A	35 – 170 A	35 – 200 A	35 – 300 A	35 – 400 A
Markierstrom Marking current	10 – 50 A	10 – 50 A	10 – 50 A	10 – 50 A	10 – 50 A
Einschaltdauer Duty cycle ²	100 %	100 %	100 %	100 %	100 %
Abmessung (LxBxH) Dimensions (LxWxH)	1030 x 570 x 1260 mm	1030 x 680 x 1450 mm	1030 x 680 x 1450 mm	1030 x 680 x 1450 mm	1030 x 680 x 1450 mm
Masse Mass	266 kg	388 kg	388 kg	488 kg	563 kg

¹ Andere Spannungen und Frequenzen auf Anfrage | other voltages and frequencies on request

² Umgebungstemperatur 40 °C | ambient temperature 40 °C

09|09|20

Auszug Schneiddaten | Extract operating data

Dicke Thickness mm	Baustahl Mild steel		Edelstahl Stainless steel		Aluminium Aluminium	
	A	mm/min	A	mm/min	A	mm/min
1	35	2600	55	5500	55	4500
2	35	1600	55	4000	55	4000
5	60	3100	55	2000	55	2700
6	90	3700	130	1600	130	3500
8	130	3700	130	1500	130	1400
10	130	3000	130	1400	130	1300
12	170	3400	170	1400	170	1500
15	170	2700	170	1100	170	1400
20	200/300	1800/2100	200/300	850/1200	200/300	1300/2800
30	200/300	1000/1200	200/300	600/860	200/300	600/1800
40	300/400	720/1200	300/400	570/750	300/400	1200/1600
50	300/400	400/800	300/400	480/550	300/400	880/1200
60	300/400	200/550	300/400	410/480	300/400	550/1000
70	300/400	150/300	300/400	280/380	300/400	450/800
80	300/400	100/210	300/400	250/330	300/400	400/600
100	400	150	400	180	400	250



Kontakt | Contact

Kjellberg Finsterwalde Plasma und Maschinen GmbH

Oscar-Kjellberg-Str. 20 | 03238 Finsterwalde | Germany | |: +49 3531 500-0 | ☎: +49 3531 500-299

sales@kjellberg.de | Copyright © 2020 Kjellberg Finsterwalde

Connect with Kjellberg – Always on!

kjellberg.de